



HEIDENHAIN

RFM

Resources For Manufacturing, Inc.



Digital Readouts

for Metrological Applications

May 2009

For many metrological applications, ranging from simple measuring stations to complex inspection systems with multiple measuring points, HEIDENHAIN supports you with the appropriate digital readouts or PC solutions.

The functionality always orients itself to the specific application. Whether it is an SPC inspection station, a tool presetter, a profile projector, a measuring microscope, or a manual coordinate measuring machine, the **digital readouts and PC solutions for metrological applications** from HEIDENHAIN are the right choice for measurement tasks. There is even a CNC option for the automation of measurement tasks.

Digital readouts from HEIDENHAIN

for manual machine tools optimally support the operator with cycles for milling, drilling and turning. You can find these digital readouts on the Internet under www.heidenhain.de or in the *Digital Readouts and Linear Encoders for Manually Operated Machine Tools* product brochure.



Digital readouts and PC solutions for metrological applications

Table of Contents

Overview		
	Selection Guide	4
Specifications		
	ND 1100 QUADRA-CHEK – for simple positioning tasks	6
	ND 1200 QUADRA-CHEK – for 2-D geometries	8
	ND 1300 QUADRA-CHEK – for convenient 2-D measurement	10
	ND 1400 QUADRA-CHEK – for manual 3-D measuring machines	12
	IK 5000 QUADRA-CHEK – universal PC package solution	14
	ND 1200T TOOL-CHEK – for tool presetters	18
	ND 2100 G GAGE-CHEK – for multipoint inspection apparatuses	20
Mounting		
	Dimensions	22
	Installation, Protective Cover	23
Accessories		
	Calibration and Demonstration Parts	24
	External Control Elements	25
	Optical Edge Detector	26
	Servo Amplifier for CNC	27
Electrical Connection		
	Interfaces	28
	Overview	
	Encoder connections	30

Selection Guide

	Monitor	Axes	Data interface	Functions
ND 1100 QUADRA-CHEK <ul style="list-style-type: none"> Positioning equipment Measuring fixtures Manual coordinate measuring machines 	Monochrome	2	USB RS-232-C	Measurement series with MIN/MAX display
		3		
		3 + Q		
ND 1200 QUADRA-CHEK <ul style="list-style-type: none"> Profile projectors Measuring microscopes 2-D measuring machines 	Monochrome	XY	USB RS-232-C	<ul style="list-style-type: none"> Measurement of 2-D features Measure Magic function Point measurement with crosshairs Programming of features and parts Graphic display of measurement results
		XYQ or XYZ		
		XYZQ		
ND 1300 QUADRA-CHEK <ul style="list-style-type: none"> Profile projectors Measuring microscopes Video measuring machines 	Color touchscreen	XY	USB RS-232-C	<ul style="list-style-type: none"> Measurement of 2-D features Measure Magic function Point measurement with crosshairs Programming of features and parts Graphic display of measurement results
		XYQ or XYZ		
		XYZQ		
ND 1400 QUADRA-CHEK <ul style="list-style-type: none"> Manual coordinate measuring machines 	Color touchscreen	XYZQ	USB RS-232-C	<ul style="list-style-type: none"> Measurement of 2-D and 3-D features Points measured via touch probe, crosshairs or rigid probing element Measure Magic function Programming of features and parts Graphic display of measurement results Five coordinate systems can be stored Touch-probe management
ND 1200T TOOL-CHEK <ul style="list-style-type: none"> Tool presetters 	Monochrome	XZ	USB RS-232-C	<ul style="list-style-type: none"> Point measurement with crosshairs 99 tool adapters and 300 tools
ND 2100G GAGE-CHEK <ul style="list-style-type: none"> Multipoint inspection apparatuses SPC inspection stations 	Color	4	USB RS-232-C	<ul style="list-style-type: none"> Programming of up to 100 parts Graphic display of measurement results Classification using tolerance and warning limits Measurement series with MIN/MAX display Entry of formulas and combinations Functions for statistical process control (SPC)
		8		
ND 200 <ul style="list-style-type: none"> Measuring fixtures Adjustment and inspection equipment SPC inspection stations 	Color	1	USB RS-232-C Ethernet (option)	<ul style="list-style-type: none"> Metrological and Statistical Functions (classification, measurement series, SPC)
IK 5000 QUADRA-CHEK Universal PC package solution for <ul style="list-style-type: none"> Profile projectors Measuring microscopes Video measuring machines Coordinate measuring machines 	PC screen	XYZQ		<ul style="list-style-type: none"> Measurement of 2-D and 3-D features (depending on the version) Point measurement with crosshairs Programming of features and parts Graphic display of measurement results Entry of tolerances Import of CAD drawings for direct comparison
		XYZ		
		XYZQ		
		XYZQ		
		XYQ		
		XYZQ		
		XYZQ		
		XYZQ		

Options/Additional functions	Model	Page
Touch probe	ND 1102	6
	ND 1103	
	ND 1104	
Optical edge detector	ND 1202	8
	ND 1203	
	ND 1204	
<ul style="list-style-type: none"> Optical edge detector Video edge detection and live image display Archiving and output of live images Zoom and light control, programmable CNC axis control and autofocus 	ND 1302	10
	ND 1303	
	ND 1304	
–	ND 1404	12
–	ND 1202T	18
–	ND 2104G	20
	ND 2108G	
Second encoder for sum/difference display, temperature compensation	ND 287	<i>Position Display Units</i> catalog
–	IK 5294	14
3-D; touch probe	IK 5293	
Optical Edge Detector	IK 5394-EG	
Video evaluation	IK 5394-2D	
CNC; optical edge detector	IK 5493	
CNC; video evaluation	IK 5494-2D	
CNC; video evaluation; touch probe	IK 5494-3D	
CNC; video evaluation; TP 200 touch probe	IK 5594	



ND 1100 QUADRA-CHEK



ND 1200 QUADRA-CHEK



ND 1300/ND 1400 QUADRA-CHEK



ND 2100G GAGE-CHEK



ND 200



IK 5000 QUADRA-CHEK

ND 1100 QUADRA-CHEK

– the Digital Readouts for Simple Positioning Tasks

The ND 1100 QUADRA-CHEK digital readouts can support up to four axes. They are mainly suited to positioning tasks on positioning equipment and measuring fixtures, as well as for retrofitting on measuring machines for data acquisition and relaying to a PC.

Description

The ND 1100 QUADRA-CHEK digital readouts have a monochrome flat-panel screen for displayed values, dialogs, inputs and soft keys. The robust, diecast aluminum enclosure meets the demands of metrology and production control.

Functions

The logical placement of the function keys and soft keys permits innovative operator guidance, which supports you when using the diverse functions.

Along with the usual functions of a digital readout, such as zeroing and setting of reference values, the ND 1100 QUADRA-CHEK units have numerous more useful functions:

- Each axis can be configured for linear or angular display
- Minimum/maximum value storage
- Simple switching between counting directions
- Continuous data output via internal clock, or upon probing

Data interfaces

You use the data interfaces to output measurement points as well as to save settings and compensation values. The ND 1100 has an RS-232-C/V.24 serial interface for communication with a PC. You can connect printers or memory media directly to the USB port.

Display format

Depending on the type of encoder connected, you can define linear or angular display individually for each axis.

X	14.5653		
Y	-8.2776		
Z	20°30'50"		
Q	324°55'30"		
Abs	MM	Menu	Preset

Minimum/maximum value storage

The ND 1100 is capable of minimum/maximum value storage in any freely selectable axis. The largest and smallest measured values of a measurement series, as well as the difference, are stored, and can be output via the data interface. This function is especially advantageous during concentricity testing.

MinMax				
Max	14.7653			
Min	14.5653			
Spannw.	0.2000			
Both	Max	Min	Neu	Preset

Touch-probe connection

Touch probes (e.g. from HEIDENHAIN or Renishaw) can be connected to the ND 1100. The digital readout automatically reads the current position value during probing, and also takes the radius of the stylus into account.

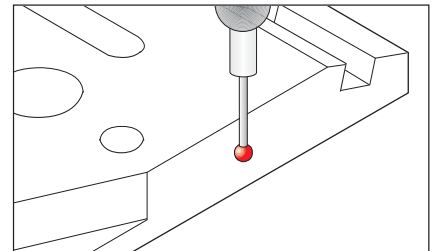

Display format of measured values

Since the universal output formats are used by various manufacturers of measuring machines, the ND 1100 can easily be retrofitted as a data logger to manually operated measuring machines. The measured values are captured by the ND, and then relayed to a connected PC for further processing.

X	12.3553 mm
Y	-8.2006 mm
Z	20.30.50 dms
Q	326.37.30 dms



	ND 1102	ND 1103	ND 1104
Axes	2	3	4
Encoder inputs*	~ 1 V _{PP} or □□TTL (other interfaces upon request)		
Subdivision factor	10-fold (only for 1 V _{PP})		
Display step¹⁾	Adjustable, max. 7 digits <i>Linear axis:</i> 1 mm to 0.0001 mm <i>Angular axis:</i> 1° to 0.0001° (00° 00' 01")		
Display	5.7" monochrome flat-panel display for position values, dialogs and inputs, and soft keys		
Functions	<ul style="list-style-type: none"> • Measurement series with MIN/MAX display • Difference between minimum and maximum (range) • Scaling factor 		
Error compensation	<ul style="list-style-type: none"> • Linear, and segmented over up to 300 points • Squareness calibration 		
Data interface	<ul style="list-style-type: none"> • RS-232-C/V.24 • USB (type A) 		
Touch-probe connection*	HEIDENHAIN touch probe or Renishaw touch probe		
Other connections	Foot switch for two functions, or remote keypad		
Accessories	Mounting base, foot switch, remote keypad, protective cover		
Main power input	100 V~ to 240 V~ (-15 % to +10 %), 43 Hz to 63 Hz		
Operating temperature	0 °C to 45 °C		
Protection EN 60529	IP 00, front panel IP 40		
Weight	ND: 1.6 kg; <i>Tilting base:</i> 3.2 kg		

* Please select when ordering

¹⁾ Depends on the signal period of the connected encoders as well as the subdivision factor

ND 1200 QUADRA-CHEK

– the Digital Readouts for 2-D Geometries

The ND 1200 digital readouts can support up to four axes, and function as measuring computers for 2-D geometries. They are mainly suited to optical comparators, measuring microscopes and 2-D measuring machines.

Description

The ND 1200 QUADRA-CHEK digital readouts have a monochrome flat-panel screen for displayed values, dialogs and inputs, graphics functions and soft keys. The robust, diecast aluminum enclosure meets the demands of metrology and production control.

Functions

The appropriate combination of defined function keys and context-dependent soft keys always provides you with a clear overview. The innovative operator guidance provides self-explanatory information about the various functions. It already supports you while setting up the coordinate system (aligning the part and specifying the datum).

Predefined features (point, line, circle) are available for measurement. The "Measure Magic" function makes measurement especially easy: it selects that feature which best matches the shape implied by the points probed. In addition, you can establish relationships (distances, angles) between features.

You can also apply tolerance values to features and relationships. Only those tolerances actually possible are offered for the selected feature. You can create or automatically record measuring programs for repeated parts. The digital readout graphically takes you to the next measurement position during program run.

The ND 1200 captures measurement points of plane contours (2-D) either manually via crosshairs or, as an option, automatically via the optical edge detector.

Data interfaces

You use the data interfaces to output measurement points as well as to load and save settings, compensation values and programs. The RS-232-C/V.24 serial interface enables communication with a PC. You can connect printers or memory media to the USB port.

Graphic display

In addition to the position values, the ND 1200 also displays the features graphically. Along with the individual measurement points, the geometrical and arithmetical deviations are also shown. Furthermore, for circles the maximum inscribed circles and minimum circumscribed circles are shown.

Tolerances

You can also apply tolerance values to any feature. Only those tolerances actually possible are offered for the selected feature. This means that a point can only be assigned a tolerance check for its position, whereas a circle can be assigned position, shape and size tolerances.

Defining features

You can use the QUADRA-CHEK digital readouts to define features yourself. For example, this could be a circle whose position and dimensions are exactly defined, or an alignment line that is at a specified angle to a measurable line.

Measure Magic

The Measure Magic function recognizes the geometric pattern based on the distribution of the measurement points, and automatically calculates which feature it is, such as a point, line or circle. If the measurement points are poorly chosen, then it may not be possible to determine the feature unambiguously. Measure Magic then chooses the more common version. You can have the feature displayed graphically, and then select from the possibilities.

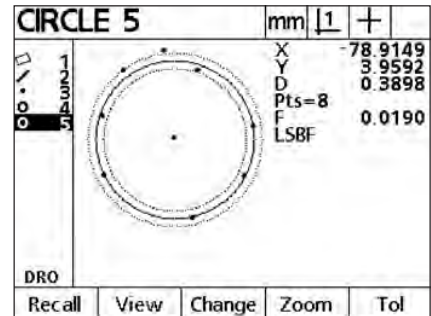

CIRCLE 2		mm	1	+
Circle Position and Size Tolerance				
Tol Type: BiDir				
	Actual	Dev		
X	174.9079	0.0079		✓
Y	-20.1577	0.0023		✓
D	58.3624	0.0004		✓
Edit	Nominal	Actual	Dev	Other

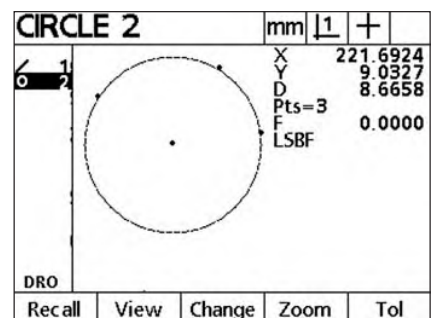
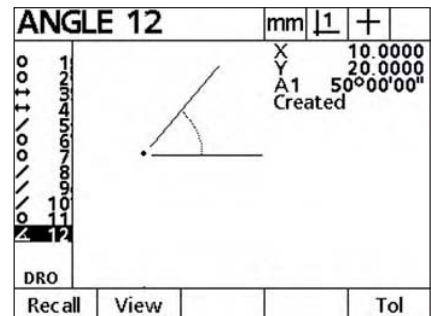

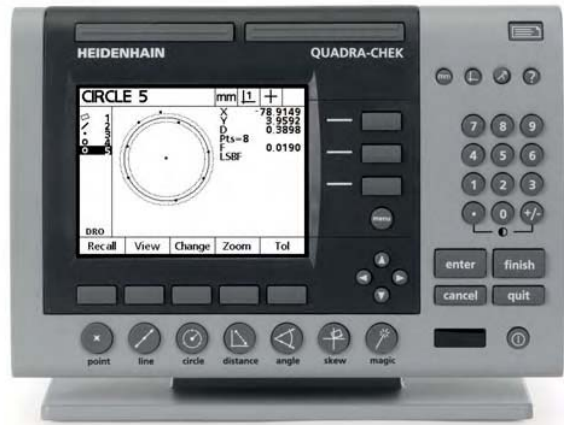

	ND 1202	ND 1203	ND 1204
Axes*	2 (XY)	3 (XYQ) or 3 (XYZ)	4 (XYZQ)
Encoder inputs*	~ 1 V _{PP} or □□TTL (other interfaces upon request)		
Subdivision factor	10-fold (only for 1 V _{PP})		
Display step¹⁾	Adjustable, max. 7 digits Linear axes XYZ: 1 mm to 0.000 1 mm Angular axis Q: 1° to 0.000 1° (00° 00' 01")		
Display	5.7" monochrome flat-panel display for position values, dialogs and inputs, graphics functions and soft keys		
Functions	<ul style="list-style-type: none"> • Measurement of two-dimensional features (2-D) • Point measurement with crosshairs • Programming of features and parts • Measure Magic: automatic recognition of geometries • Graphic display of measurement results • Entry of tolerances • Measurement series with MIN/MAX display 		
Edge detector*	Automatic capture of measurement points via optical edge detector (option)	Upon request	
Error compensation	<ul style="list-style-type: none"> • Linear, and segmented over up to 150 points • Squareness calibration • Matrix compensation over up to 30 x 30 points 		
Data interface	<ul style="list-style-type: none"> • RS-232-C/V.24 • USB (type A) 		
Other connections	<ul style="list-style-type: none"> • Foot switch for two functions, or remote keypad • Optical edge detector (only if the option is selected) 		
Accessories	Mounting base, foot switch, remote keypad, fiber-optic cables holder, demo part, protective cover		
Main power input	100 V~ to 240 V~ (-15 % to +10 %), 43 Hz to 63 Hz		
Operating temperature	0 °C to 45 °C		
Protection EN 60529	IP 00, front panel IP 40		
Weight	ND: 1.6 kg; Tilting base: 3.2 kg		

* Please select when ordering

¹⁾ Depends on the signal period of the connected encoders as well as the subdivision factor

ND 1300 QUADRA-CHEK

– the Digital Readouts for Convenient 2-D Measurement

The ND 1300 QUADRA-CHEK digital readouts can support up to four axes. They function as measuring computers with 2-D acquisition of measurement points, suiting them for measuring microscopes, measuring projectors and profile projectors, as well as for video measuring machines if the video edge detection option is selected.

Description

The digital readouts of the ND 1300 series are characterized by the large, color touchscreen. Their enclosures consist of robust, diecast aluminum.

Functions

The innovative operator guidance provides self-explanatory information about the various functions. It already supports you while setting up the coordinate system (aligning the part and specifying the datum).

Predefined features (point, line, circle, slot and rectangle) are available for measurement. The "Measure Magic" function makes measurement especially easy. In addition, you can establish relationships (distances, angles) between features.

You can create or automatically record measuring programs for repeated parts. The digital readout graphically takes you to the next measurement position during program run.

Depending on the option installed, the ND 1300 saves measurement points of plane (2-D) contours either automatically or manually via crosshairs, optical edge detection, or a video camera. The integrated image processing function of the video option provides a special benefit: the video image is shown on the screen in real time, can be saved and output via the data interface. The digital readout even assumes complete control of the illumination and the motor zoom.

Data interfaces

You use the data interfaces to output measurement points as well as to load and save settings, compensation values and programs. The RS-232-C/V.24 serial interface enables communication with a PC. You can connect printers or memory media to the USB port.

Clearly structured display

The large, color, flat-panel touchscreen enables simple operation with intuitive operator guidance, since in each mode only those functions actually available are offered for selection. The numeric keypad and the few basic function keys are located in ergonomically favorable positions.

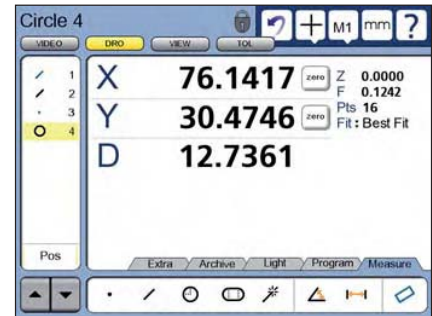

Saving of measurement points

The ND 1300 readouts are designed for 2-D measurements. You are provided with various tools with which you can manually or automatically save measurement points. For automatic saving of measurement points you simply roughly approach the position. The actual edge is automatically detected by the active tool (option). This objective saving of the measurement point permits a high degree of repeatability. This makes it possible for you to work quickly and reliably, without tiring, while at the same time maintaining a low degree of measurement uncertainty.

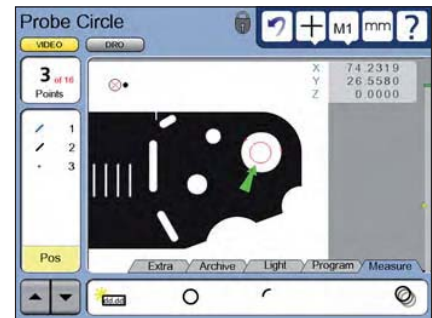

Integrated image processing

The ND 1300 with video option optimally combines in one unit the functions of a position display unit with the capability of displaying the image of the measured object directly on the screen. The separate PC with a frame grabber or monitor with crosshair generator that you would normally need is not necessary. Video cameras with S-Video or composite interfaces can be connected.

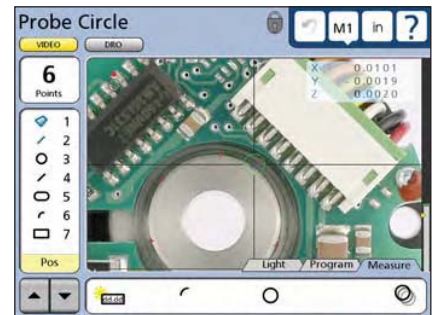

Axis positioning

The CNC option lets the ND 1300 work as a full-fledged control, directly controlling the positioning of the X, Y, Z and Q axes. Servo and stepper motors can be connected. The necessary servo amplifiers for two or three axes are available as accessories.

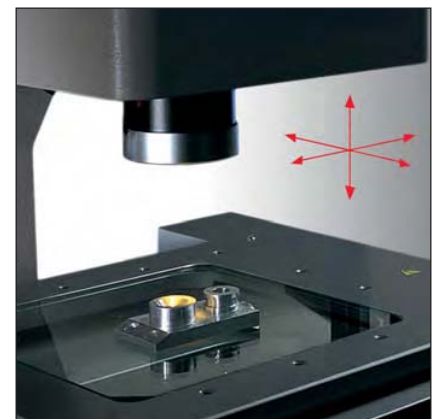



	ND 1302	ND 1303	ND 1304
Axes*	2 (XY)	3 (XYQ) or 3 (XYZ)	4 (XYZQ)
Encoder inputs*	~ 1 V _{PP} or □□TTL (other interfaces upon request)		
Subdivision factor	10-fold (only for 1 V _{PP})		
Display step¹⁾	Adjustable, max. 7 digits Linear axes XYZ: 1 mm to 0.000 1 mm Angular axis Q: 1° to 0.000 1° (00° 00' 01")		
Display	8.4" color flat-panel display (touchscreen); resolution: SVGA 800 x 600 pixels, for position values, dialogs and inputs, graphics functions, soft keys, and display of video images with the <i>Video</i> option		
Functions	<ul style="list-style-type: none"> • Measurement of two-dimensional features (2-D) • Point measurement with crosshairs • Programming of features and parts • Measure Magic: automatic recognition of geometries • Graphic display of measurement results • Entry of tolerances 		
Edge detector* (option)	<ul style="list-style-type: none"> • Automatic saving of measurement points via optical edge detector 		
Video* (Option)	<ul style="list-style-type: none"> • Automatic saving of measurement points via video edge detection • Manual autofocus (only for Z axis) • Show live images • Archive and output live images (<i>Archive</i> option, only with the <i>Video</i> and <i>Zoom</i> options) • Zoom and light control, programmable (<i>Zoom</i> option, only with the <i>Video</i> option) 		
CNC* (Option)	<ul style="list-style-type: none"> • Automation of measurement tasks • Axis control (for XYZQ) for servo and stepper motors • Autofocus via step-motor control 		
Error compensation	<ul style="list-style-type: none"> • Linear, and segmented over up to 1000 points • Squareness calibration • Matrix compensation over up to 30 x 30 points 		
Data interface	<ul style="list-style-type: none"> • RS-232-C/V.24 • USB (type A) 		
Other connections	<ul style="list-style-type: none"> • Foot switch for two functions, or remote keypad • Video connection for S-Video and composite (<i>Video</i> option) • Light control over six light sources and zoom control (for <i>Video</i> and <i>Zoom</i> options) • CNC outputs and inputs for joystick (for <i>CNC</i> option) 		
Accessories	Mounting base, foot switch, fiber-optic cables holder, servo amplifier, calibration standard, demo parts, protective cover		
Main power input	100 V~ to 240 V~ (-15 % to +10 %), 43 Hz to 63 Hz		
Operating temperature	0 °C to 45 °C		
Protection EN 60529	IP 00, front panel IP 40		
Weight	ND: 1.6 kg; Tilting base: 3.2 kg		

* Please select when ordering; the options *Edge detector* and *Video* cannot be combined

¹⁾ Depends on the signal period of the connected encoders as well as the subdivision factor

ND 1400 QUADRA-CHEK

– the Digital Readout for Manual 3-D Measuring Machines

The ND 1400 QUADRA-CHEK digital readout supports four axes: in addition to the linear axes XYZ it features an auxiliary axis Q solely for angular display. The readout is designed specifically for manual coordinate measuring machines, and can capture two- and three-dimensional features with its measuring computer functionality.

Description

The ND 1400 digital readout is characterized by the large, color touchscreen. Its enclosure consists of robust, diecast aluminum.

Functions

The innovative operator guidance provides self-explanatory information about the various functions. It already supports you while setting up the coordinate system (ascertaining the reference plane, aligning the part and specifying the datum).

Predefined features (point, line, circle, slot, rectangle, plane, cylinder, cone, sphere) are available for measurement. The "Measure Magic" function makes measurement especially easy: it selects that feature which best matches the shape implied by the points probed. In addition, you can establish relationships (distances, angles) between all features.

You can create or automatically record measuring programs for repeated parts. The digital readout graphically takes you to the next measurement position during program run.

You can also use the ND 1400 to measure 3-D features, such as surfaces, cylinders, cones, etc. The measurement points are probed with a touch probe. If a triggering touch probe is used the values are saved automatically. With rigid probing elements a key must be pressed.

The measured features can be clearly displayed either in three dimensions or in one of the three projection planes.

Data interfaces

You use the data interfaces to output measurement points as well as to read and transmit settings, compensation values and programs. The RS-232-C/V.24 serial interface enables communication with a PC. You can connect printers or memory media to the USB port.

Clearly structured display

The large, color, flat-panel touchscreen enables simple operation with intuitive operator guidance, since in each mode only those functions actually available are offered for selection. The numeric keypad and the few basic function keys are located in ergonomically favorable positions.

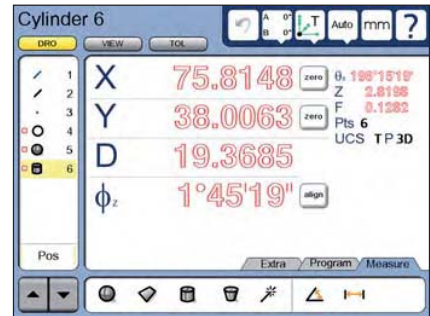

Measuring 3-D contours

In addition to the flat geometric features, such as points, lines, circles, etc., you can also use the ND 1400 to measure 3-D shapes, e.g. cylinders or cones. The screen displays the feature in three dimensions. Colored highlighting of each measurement point lets you identify form errors and any filtered measured values at a glance. The ND 1400 also permits 3-D position and form tolerances, such as flatness and parallelism.

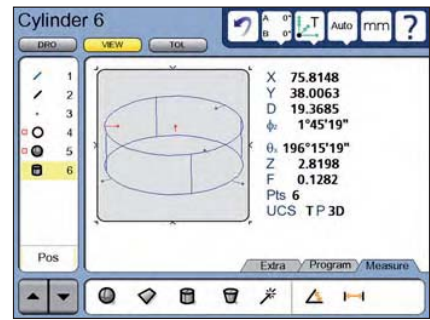

Working with the touch probe

The ND 1400 also supports you optimally while working with touch probes. You can instantaneously call commercial probing elements (normal stylus, star stylus), as well as rigid and tiltable probing heads, all of which are managed in a library, via the touchscreen. During probing the ND automatically takes the direction of probing into account, as well as the length and diameter of the stylus. Even complex parts can be rapidly measured with the five available coordinate systems.

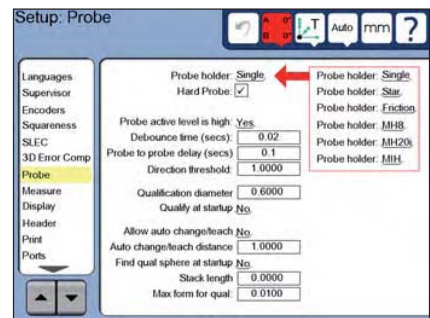

Saving of measurement points

The ND 1400 saves the measurement points via the touch probe of the coordinate measuring machine. A triggering 3-D touch probe is connected directly to the digital readout, and the measured value is transferred automatically. With a rigid probing element the measured value must be saved by pressing a key. You can use the comprehensive input menu to define numerous parameters.

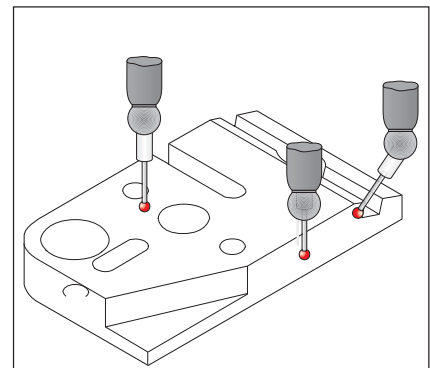



	ND 1404
Axes	4 (XYZQ)
Encoder inputs*	\sim 1 V _{PP} or \square TTL (other interfaces upon request)
Subdivision factor*	10-fold (only for 1 V _{PP})
Display step¹⁾	Adjustable, max. 7 digits <i>Linear axes XYZ:</i> 1 mm to 0.0001 mm <i>Angular axis Q:</i> 1° to 0.0001° (00° 00' 01")
Display	8.4" color flat-panel display (touchscreen); resolution: SVGA 800 x 600 pixels, for position values, dialogs and inputs, graphics functions and soft keys
Functions	<ul style="list-style-type: none"> • Measurement of two-dimensional and three-dimensional features (3-D) • Points measured via crosshairs or rigid probing element • Automatic acquisition of measurement points via touch probe • Programming of features and parts • Measure Magic: automatic recognition of geometries • Graphic display of measurement results, either three-dimensional or in the three projection planes • Entry of tolerances • Five coordinate systems can be stored • Touch-probe management for the various stylus shapes
Error compensation	<ul style="list-style-type: none"> • Linear, and segmented over up to 1000 points • Squareness calibration • Matrix compensation over up to 30 x 30 points
Data interface	<ul style="list-style-type: none"> • RS-232-C/V.24 • USB (type A)
Touch-probe connection*	HEIDENHAIN touch probe or Renishaw touch probe
Other connections	Foot switch for two functions
Accessories	Mounting base, foot switch, 3-D demo part, protective cover
Main power input	100 V~ to 240 V~ (-15 % to +10 %), 43 Hz to 63 Hz
Operating temperature	0 °C to 45 °C
Protection EN 60529	IP 00, front panel IP 40
Weight	<i>ND:</i> 1.6 kg; <i>Tilting base:</i> 3.2 kg

* Please select when ordering

¹⁾ Depends on the signal period of the connected encoders as well as the subdivision factor

IK 5000 QUADRA-CHEK

– the Universal PC Package Solution for Measuring Machines

IK 5000 QUADRA-CHEK, the universal PC package solution for 2-D and 3-D measuring tasks, is equally suitable for initial equipping on a machine as well as for retrofitting. It is available in versions for three or four axes, and the optional expansion stages make it ready for all coordinate measuring technology applications and for video measuring microscopes. You can use it to measure two- and three-dimensional geometries and their relationships.

Description

IK 5000 QUADRA-CHEK consists of the IK 5000 slot card for the PC as well as the additional necessary slot covers, and the corresponding PC software. Once installed on your PC you will have a powerful measuring station.

System requirements

The following is necessary to run QUADRA-CHEK:

- PC: ≥ dual-core Pentium, 2.66 GHz
- Operating system: Windows XP or Vista
- RAM: ≥ 1GB
- Hard disk: At least 500 MB available
- One PCI slot and one or two additional empty slots (depending on the version)
- Screen:
Resolution at least 1024 x 768 pixels;
for the *video function*: 22" widescreen,
resolution at least 1680 x 1050 pixels

Configuration

Various versions of the IK 5000 are available. Please see the configuration table for the model designations and various functions supported.

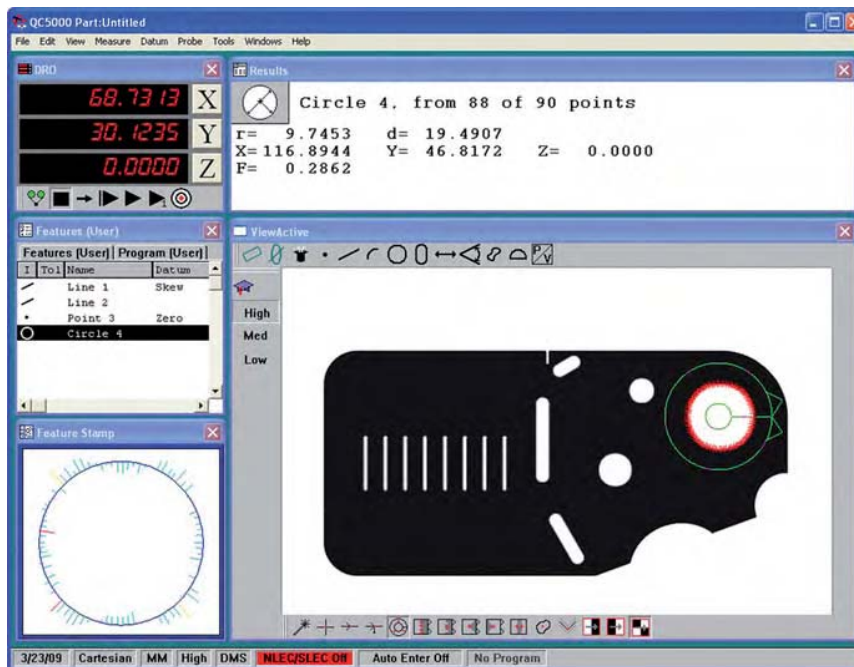

User interface

The IK 5000 QUADRA-CHEK screen shows various configurable windows and tool fields for clear and simple operation.

The **ViewActive** window shows the measured features with the accepted measurement points. You can also define relationships here.

The **Video** window (only in the version with video evaluation) shows the video image in real time.

The **Template** windows list all measured features, relationships and constructed features together with their values and tolerances in tables.

The element currently being measured is shown in the **Feature Stamp** window. The **Results** window contains all corresponding information.

The current measurement position is shown in the **DRO** window.

	IK 5294	IK 5293	IK 5394-EG	IK 5394-2D	IK 5493	IK 5494-2D	IK 5494-3D	IK 5594
Axes	4 XYZQ	3 XYZ	4 XYZQ	4 XYZQ	3 XYQ	4 XYZQ	4 XYZQ	4 XYZQ
2-D geometries	●	●	●	●	●	●	●	●
3-D geometries	–	●	–	–	–	–	●	●
Optical edge detector	–	–	●	–	●	–	–	–
Video evaluation	–	–	–	●	–	●	●	●
Light/zoom control	–	–	–	●	–	●	●	●
Autofocus	–	–	–	–	–	●	●	●
Touch probe	–	●	–	–	–	–	●	TP200
CNC function	–	–	–	–	●	●	●	●



	IK 5000
Axes¹⁾	3 (XYQ), 3 (XYZ) or 4 (XYZQ)
Encoder inputs*	~ 1 V _{PP} or □□TTL (other interfaces upon request)
Subdivision factor	Up to 100-fold, selectable via dip switch; default setting: 50-fold (only for 1 V _{PP})
Display step²⁾	Adjustable, max. 7 digits <i>Linear axes XYZ:</i> 1 mm to 0.0001 mm <i>Angular axis Q:</i> 1° to 0.0001° (00° 00' 01")
Display	Via PC screen
Functions	<ul style="list-style-type: none"> • Measurement of two-dimensional features (2-D) • Measurement of three-dimensional features (3-D)¹⁾ • Point measurement with crosshairs • Programming of features and parts • Measure Magic: automatic recognition of geometries • Graphic display of measurement results • Entry of tolerances
Edge detector ¹⁾	<ul style="list-style-type: none"> • Automatic saving of measurement points via optical edge detector
Video ¹⁾	<ul style="list-style-type: none"> • Automatic saving of measurement points via video edge detection • Manual autofocus • Show live images • Archiving and output of live images • Zoom and light control, programmable (with the <i>Light/Zoom</i> version) • Video connection for digital USB camera (with the <i>Video</i> version) • Light control over six light sources and zoom control (with the <i>Video</i> and <i>Light/Zoom</i> versions)
CNC ¹⁾	<ul style="list-style-type: none"> • Automation of measurement tasks • Axis control (for XYZQ) for servo and stepper motors • Autofocus via stepper-motor control (Z axis) • CNC outputs and inputs for joystick
Error compensation	<ul style="list-style-type: none"> • Linear, and segmented over any number of points • Squareness calibration • Matrix compensation over up to 50 x 50 points
Other connections	<ul style="list-style-type: none"> • Foot switch for two functions
Accessories	Foot switch, fiber-optic cables, holder for fiber-optic cables, servo amplifier, calibration standard, demo part, distribution cable
PC interface	PCI
Dimensions	100 mm x 250 mm

* Please select when ordering

¹⁾ See the configuration table for possible combinations

²⁾ Depends on the signal period of the connected encoders as well as the subdivision factor

IK 5000 QUADRA-CHEK

– Functions

The innovative operator guidance provides self-explanatory information about the various functions. It already supports you while setting up the coordinate system (aligning the part and specifying the datum).

Various predefined features are available for measurement, depending on the version:

2-D saving: Point, line, circle, slot, rectangle
3-D saving: Plane, cylinder, cone, sphere
The "Measure Magic": it selects that feature which best matches the shape implied by the points probed.

With IK 5000 QUADRA-CHEK you can define features yourself (for example, a circle whose position and dimensions are exactly specified). In addition, you can establish relationships (distances, angles) between features.

Measuring programs that you create yourself or record automatically simplify the efforts necessary for repeated parts. The digital readout graphically takes you to the next measurement position during program run.

Depending on the version, IK 5000 QUADRA-CHEK saves measurement points of plane (2-D) contours either automatically or manually via crosshairs, via optical edge detection, or via a video camera.

For 3-D contours, such as planes, cylinders, cones and spheres, the measurement points are saved by probing with a touch probe. If a triggering touch probe is used the values are saved automatically. With rigid probing elements a key must be pressed.

The measured features can be clearly displayed either in three dimensions or in one of the three projection planes.

Multi-sensor scanning

Along with the usual method for saving measurement points, the IK 5494 and IK 5594 versions permit multi-sensor scanning: in addition to the video camera, the measuring machine is also equipped with a touch probe. You can then use the touch probe to measure 3-D features on the object, and enjoy the advantages of video evaluation for 2-D features. The integrated probe library manages the various measurement tools for you, whether they be optical, video, laser or touch-probe systems.

Constructed features

QUADRA-CHEK gives you several possibilities for determining dimensions:

- Measuring the features
- Calculating the features (e.g. the center point of a measured circle)
- Establishing a relationship between features (e.g. distance between two circle center points, angle between two lines)

However, you can also construct new features from existing features and from relationships. The properties of these constructed features can then be seen directly in the parts view.

Data management

The integrated data-report generator for customized forms, databases and tolerance checks is used to archive, export and import data in numerous formats. Use the integrated spreadsheets for complex and non-standard calculations.

Simply send your customized reports to a printer, or make the data available to other users in a database.

Functional ViewActive window

QUADRA-CHEK provides you with a comprehensive, graphical ViewActive window. You can choose between a 3-D view, or a projection in the XY, YZ or ZX planes. Additionally, you can magnify, reduce, zoom, shift or rotate the views. You can define tolerances and constructed features in any view. The "pass/fail" color coding makes it easy to determine whether the part matches the specifications.

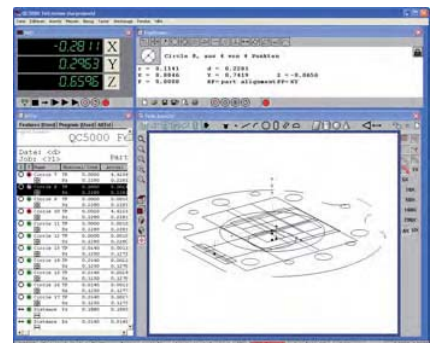
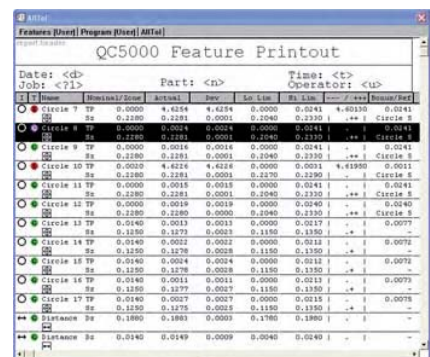
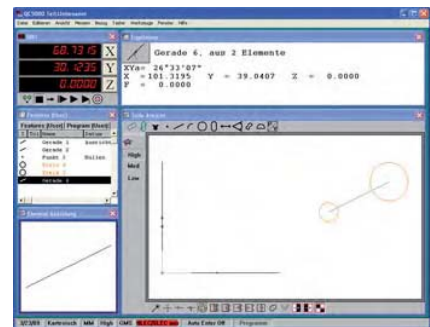
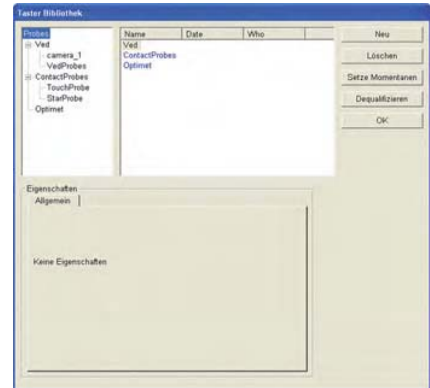

Programming of parts

Difficult and repetitive measuring tasks can be simplified with the aid of a program that you either create yourself or record automatically during measurement of the first part. QUADRA-CHEK learns the reference points, the sequence of measurements, tolerances and data-output commands. QUADRA-CHEK visually leads you to the features to be probed when the program is run. The program view also provides you with an optimum overview of the process.

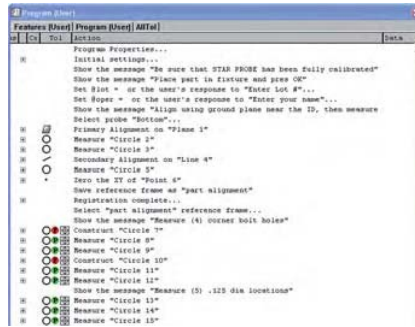

Excerpt from the possibilities for the construction of features:

2-D possibilities

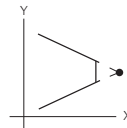

Intersection of two lines

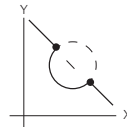

Intersection of line and circle

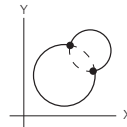

Intersection of two circles

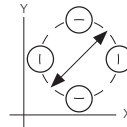

Hole circle formed from three or more circles

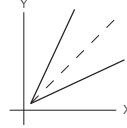

Bisector of two lines

Integrated image processing

The integrated image processing function included with the video-function versions provides a special benefit: the video image is shown on the screen in real time and can be saved. QUADRA-CHEK can even assume complete control of the illumination and the motor zoom. A digital USB camera can be connected.

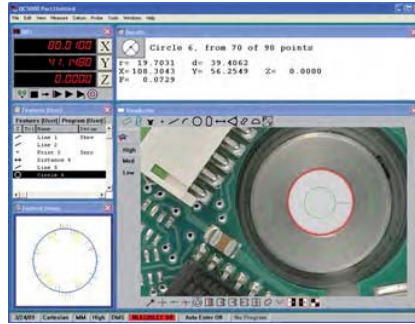

In order to quickly and directly compare the actual status and nominal status, import the parts drawing in DXF or IGS format, and place it over the video image.

Axis positioning

The CNC versions of the IK 5000 QUADRA-CHEK work as full-fledged controls, directly controlling the positioning of the X, Y, Z and Q axes. Servo and stepper motors can be connected. The necessary servo amplifiers for two or three axes are available as accessories.



Automating

Programs running in combination with the CNC function of IK 5000 QUADRA-CHEK run automatically. This minimizes the effects of subjective assessments, and increases data throughput noticeably. By automating series of measurements and complex procedures, you spare yourself the strain of performing repetitive measuring tasks.

3-D possibilities

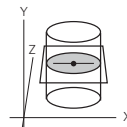

Intersection of cylinder and surface

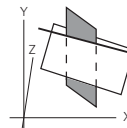

Plane from plane and 3-D line

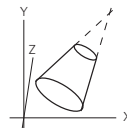

Taper angle

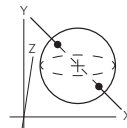

Intersection of sphere and line

ND 1200T TOOL-CHEK

– the Digital Readout for Tool Presetters

The TOOL-CHEK ND 1200T digital readout is designed specifically for tool presetters. It supports X and Z axes.

Description

The ND 1200T has a monochrome flat-panel display. The robust, diecast aluminum enclosure meets the demands of production floors.

Functions

The self-explanatory user guidance of the TOOL-CHEK ND 1200T digital readout provides you with optimum support for all functions.

You can define up to 99 tool adapters for the tool holder. You can select either an absolute reference point, or one that refers to a master adapter. You can define the axis association and counting direction separately for each adapter.

Tool measurement usually consists of measuring the length and diameter or radius of a tool. You can also measure radii (e.g. for spherical cutters) and angles (e.g. for indexable inserts or lathe tools). The ND 1200T stores up to 300 tools. You can respectively show and print each actual value, nominal value and deviation.

You can group various tools, e.g. those that are necessary for machining a certain part. Create this setup plan either by selecting the tools from the tool list, or by measuring each tool.

For tools that are too large to be shown on the projector, such as teeth with a radius, you can freeze an axis for measurement. If a tool has more than one tooth, then you use the incremental function to ascertain the tool data in reference to the master tooth as well.

Data interfaces

You use the data interfaces to transmit the tool data and to load and save settings, compensation values and saved tools. The RS-232-C/V.24 serial interface enables communication with a PC. You can connect printers or memory media to the USB port.

Measuring radii and angles

You probe several points with the crosshairs in order to measure the radius. The digital readout calculates the radius and any form error from this. In order to measure a cutting edge angle, probe the two sides of the angle at two points each. The results are the intersection of the two lines as well as the inside angle "A".

T	00	mm
⊖	X	4.769
⊖	Z	0.111
	r 0.145	F 0.000
Actual	Center	C Max

Label printing

You can connect various label printers via the USB port. The control commands necessary for this are already set, and can be called via the menu function.

Print	mm
About	Auto Label Yes
Display	Auto Report No
Encoders	Label Format Metronics1
Hot Keys	Pre Line
Print	Post Line 10 13
Form Chars	Pre Form
Ports	Label Lines 5
Supervisor	Skip Lines 0
Squareness	Label Indent 0
LEC	
List	

Tool list

You can also store the data of all measured and numbered tools, and even print this data in a clearly structured list. Use the menu to determine which information is included in the list.

TOOL-#	SG	POT	Z-ACT.	X-ACT.	Z-NOM.	X-NOM.	Z-DEV.	X-DEV.	R/D	I/MM
10	01	4	100.1000	28.1000	0.0000	0.0000	100.1000	28.1000	D	mm
20	01	5	100.1400	29.9400	0.0000	0.0000	100.1400	29.9400	D	mm
30	01	6	99.9400	29.4600	0.0000	0.0000	99.9400	29.4600	D	mm
40	01	7	100.1200	29.8000	0.0000	0.0000	100.1200	29.8000	D	mm
50	01	8	100.1500	29.5600	0.0000	0.0000	100.1500	29.5600	D	mm
60	01	10	99.8800	30.2000	0.0000	0.0000	99.8800	30.2000	D	mm



	ND 1202T
Axes	2 (XZ)
Encoder inputs*	\sim 1 V _{PP} or \square TTL (other interfaces upon request)
Subdivision factor*	10-fold (only for 1 V _{PP})
Display step¹⁾	Adjustable, max. 7 digits <i>Linear axis:</i> 1 mm to 0.0001 mm <i>Angular axis:</i> 1° to 0.0001° (00° 00' 01")
Display	5.7" monochrome flat-panel display for position values, dialogs and inputs, and soft keys
Functions	<ul style="list-style-type: none"> • Point measurement with crosshairs • 99 tool adapters • Memory for 300 tools • Counting direction and axis assignment depend on the adapter • Radius/diameter switching • Entry of tolerances • Circle and angle measurement
Error compensation	<ul style="list-style-type: none"> • Linear, and segmented over up to 150 points • Parallelism error
Data interface	<ul style="list-style-type: none"> • RS-232-C/V.24 • USB
Other connections	Foot switch for two functions, or remote keypad
Accessories	Mounting base, foot switch, remote keypad, protective cover
Main power input	100 V~ to 240 V~ (-15 % to +10 %), 43 Hz to 63 Hz
Operating temperature	0 °C to 45 °C
Protection EN 60529	IP 00, front panel IP 40
Weight	ND: 1.6 kg; <i>Tilting base:</i> 3.2 kg

* Please select when ordering

¹⁾ Depends on the signal period of the connected encoders as well as the subdivision factor

ND 2100G GAGE-CHEK

– the Digital Readouts for Multipoint Inspection Apparatuses

The ND 2100G GAGE-CHEK readouts are versatile metrology displays for measuring and inspection tasks in manufacturing and quality assurance. With inputs for up to eight encoders, they are predestined for multipoint measurements from simple pass/fail detection up to complex SPC evaluation.

Description

The ND 2100G readouts have a robust, diecast aluminum enclosure, and a keyboard suited to their environment. A large, graphic, color screen displays the measured values, the soft-key row and other information.

Functions

The inputs can be assigned and combined as desired with mathematical, trigonometric or statistical formulas. This makes it possible to measure even complex dimensions such as thickness, flatness, volume and more. The results are displayed numerically or graphically as a color bar graph or a dial, or archived for statistical process control (SPC).

The GAGE-CHEK can be configured for basic or advanced applications. Soft keys and hot keys can be adapted as required. The Min/Max function of the ND 2100G readouts monitors and stores the highest and lowest measured or calculated value. Warning and tolerance limits can be assigned to each display value. Results outside of the tolerance are marked with a different color. An acoustic alarm sounds simultaneously. Tolerance values, SPC parameters and custom formulas are stored for individual parts.

GAGE-CHEK can manage up to 100 parts, each with up to 16 visible measurement features and 16 hidden measurement features. Rapid acquisition of measurement data monitors dynamic events such as the eccentricity of a rotating shaft.

Data interfaces

The GAGE-CHEK features various interfaces for communicating with parent systems:

- RS-232-C/N/24 for PC, also for remote operation of the GAGE-CHEK
- USB

Position display

The display values appear in large, easy-to-read numbers. Values outside the tolerance are color-coded, immediately notifying you of errors.

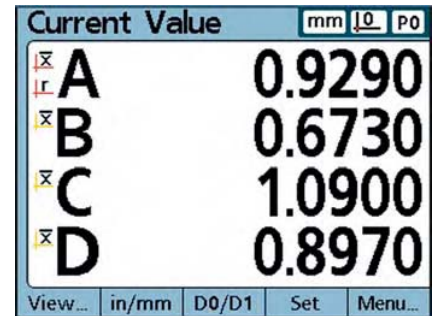

Bar graph

You can select to have the values shown as a color-enhanced vertical or horizontal bar graph. The defined warning limits and tolerance limits provide instant feedback. If these limits are exceeded, the column color changes from green to yellow or red, informing you explicitly of critical dimensions.

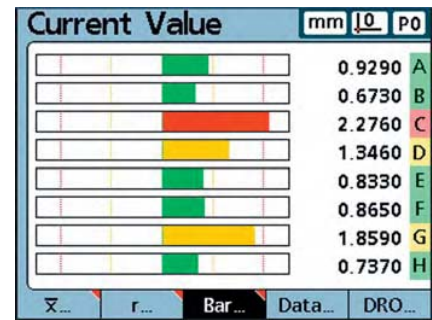

SPC and data storage

GAGE-CHEK includes integrated SPC studies such as mean value charts (X bar) and range charts (R). Min, max, sigma, cp and cpk are also calculated, and are clearly displayed as a graph or histogram. Historical raw data can be saved in a tabular numeric display. Each dimension and all data are time and date stamped.

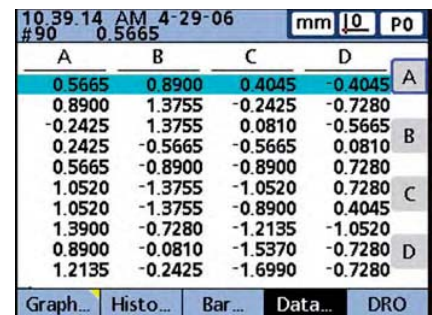

Formulas and combinations

You can use mathematical and trigonometric formulas, as well as logical conditions, to combine individual measured values or measurement sequences with each other, and so create complex calculations. This can be used, for example, to calculate and display the circumference of a turned part, the volume of a cube, or the angle between two cams, and also to assign tolerance limits to these values.

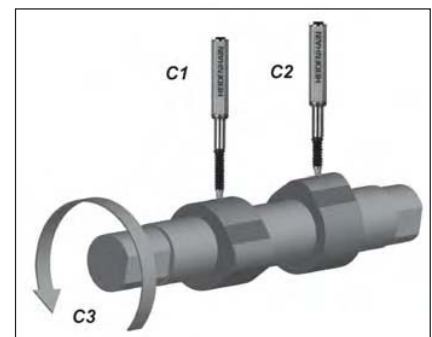



	ND 2104G	ND 2108G
Axes	4	8
Encoder inputs*	~ 1 V _{PP} or □□TTL (other interfaces upon request)	
Subdivision factor	10-fold (only for 1 V _{PP})	
Display step¹⁾	Adjustable, max. 7 digits Linear axis: 1 mm to 0.00001 mm Angular axis: 1° to 0.0001° or 00° 00' 01"	
Display	5.7" color flat-panel display for position values, dialogs and inputs, graphics functions and soft keys	
Functions	<ul style="list-style-type: none"> • Part-programming of up to 100 parts • Graphic display of measurement results • Classification using tolerance and warning limits, with display as a bar graph • Measurement series with MIN/MAX display • Mathematical and trigonometric formulas • Functions for statistical process control (SPC) • Graphic display of measurement results and distribution • Data storage of values and formulas 	
Error compensation	<ul style="list-style-type: none"> • Linear, and segmented over up to 60 points 	
Data interface	<ul style="list-style-type: none"> • RS-232-C/V.24 • USB 	
Switching inputs	5 TTL inputs (freely definable)	
Switching outputs*	12 TTL outputs (freely definable) Two relay outputs, or one input for edge detector	
Other connections	Foot switch for two functions, or remote keypad	
Accessories	Mounting base, foot switch, remote keypad, protective cover	
Main power input	100 V~ to 240 V~ (-15 % to +10 %), 43 Hz to 63 Hz	
Operating temperature	0 °C to 45 °C	
Protection EN 60529	IP 40	
Weight	ND: 1.6 kg; Tilting base: 3.2 kg	

* Please select when ordering

¹⁾ Depends on the signal period of the connected encoders as well as the subdivision factor

Mounting

Dimensions of ND 1000/ND 2000

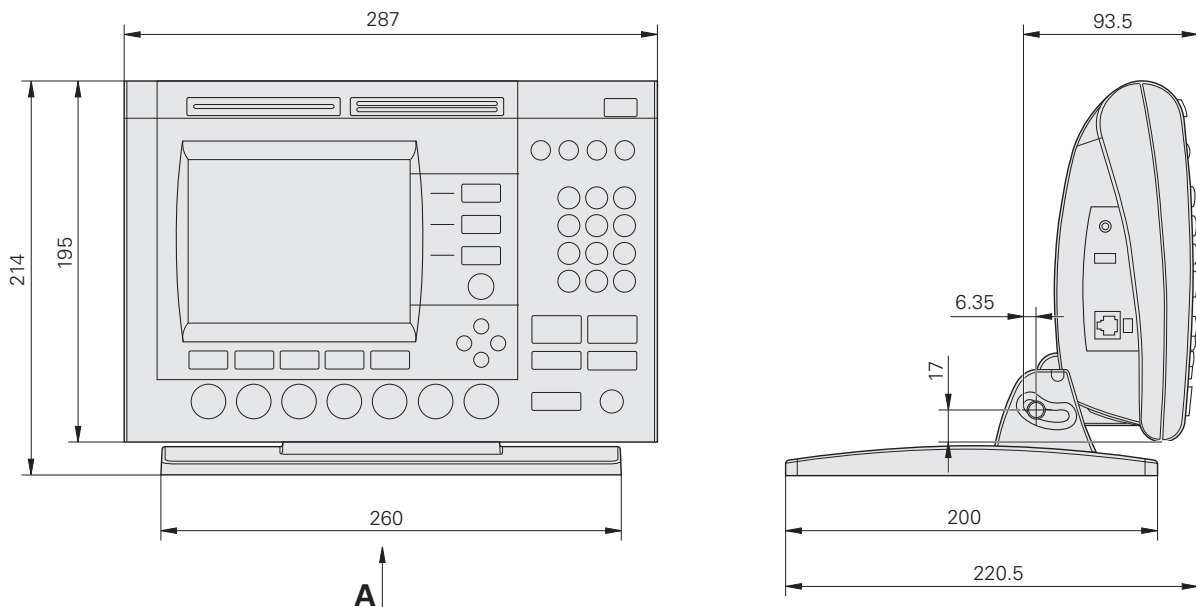

Dimensions in mm



Tolerancing ISO 8015

ISO 2768 - m H

< 6 mm: ± 0.2 mm

Mounting and Protection

Mounting

The ND 1000 and ND 2000 display units were conceived as upright units. There are several possible mounting configurations:

- Tilting base
- Mounting base

Tilting base

The tilting base is included in delivery. It can be used to tilt the display forward and backward by up to 20°. It can be attached with M5 screws.

Mounting base (accessory)

With the aid of a mounting base you can set up the ND 1000 and ND 2000 either on the machine or on a mounting arm.

ID 682419-01

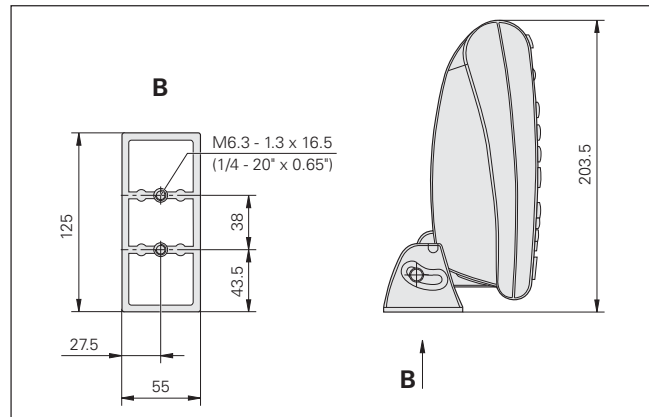
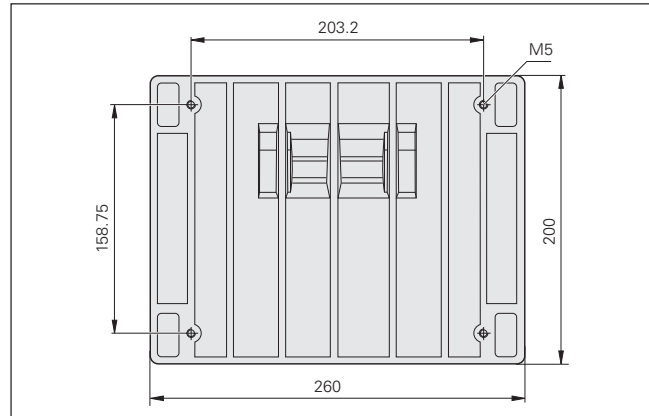

Protective cover (accessory)

Protective covers are available accessories in order to protect the keyboard and screen of the ND 1000/ND 2000 from becoming soiled. The display can still be easily read through the transparent protective covers. They fit themselves optimally to the front of the unit, without impairing the ease of operation.

ND 11xx; 1/2 axes	ID 681051-02
ND 11xx; 3/4 axes	ID 681051-03
ND 12xx	ID 681051-01
ND 21xx	ID 681051-04



Accessories

Calibration and Demonstration Parts

HEIDENHAIN offers various calibration parts as accessories in order to calibrate the optical and tactile edge detection methods.

Calibration standard

For the calibration of video measuring machines, measuring microscopes and profile projectors. It can be traced back to the National Institute of Standards and Technology (NIST).

ID 681 047-01

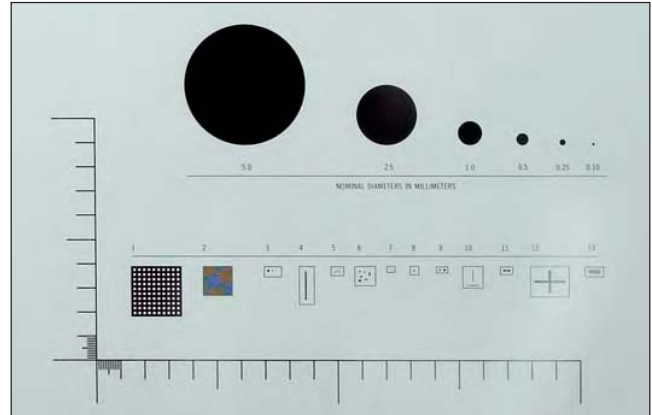

2-D demo part

The 2-D demo part is included with the readouts and the software package. The application examples in the ND 1200 and ND 1300 User's Manuals are based on this part. It can be reordered if a replacement is necessary.

ID 681 047-02



3-D demo part (accessory)

Demo part for touch-probe applications. The examples in the ND 1400 User's Manual are based on this part.

ID 681 048-01



3-D demo part for multi-sensor scanning (accessory)

Demo part specifically for applications that combine touch-probe systems and video edge detection. It is used for the examples in the IK 5000 User's Manual.

ID 681 048-02



External Control Elements

The digital readouts and the PC package can be operated easily and intuitively. However, remote operability may also be useful and convenient in some situations. The following components are available for remote operation:

Foot switch (accessory)
With two freely assignable keys
Cable length: 2.4 m

For ND with RJ 45 connector
ID 681 041-01

For IK 5000 with 3-pin DIN connector
ID 681 041-02

Remote keypad (accessory)
For remote operation of the digital readouts; features a numeric keypad and "enter" and "finish" keys; cable length: 4.5 m; with RJ 45 connector.

ID 681 043-01

Joystick (accessory)
For remote operation and sensitive traversing of axes for ND 1300 and IK 5000. With 15-pin D-sub connector.

Without trackball ID 681 044-02
With trackball ID 681 044-01



Accessories

Optical Edge Detector

Two fiber-optic cables are necessary for edge detection with the optical edge detector. One fiber-optic cable is attached to the projection screen with a transparent holder. The second cable is attached near the transmitted light source so that the fibers point toward the light source. The following accessory components are required.

Fiber-optic cable (accessory)

With one right-angle end and an SMA connector (subminiature A) for ND or IK.
Bend radius: ≥ 25 mm
Temperature: ≤ 100 °C
Lengths: 2 m, 3 m, 5 m

ID 687049-xx



Holder (accessory)

With a hole for accepting the right-angle end of fiber-optic cables. Transparent design so that it can be attached to the projection screen.
Lengths: 350 mm, 600 mm, 760 mm

ID 681505-xx



Fiber-optic cable connector (accessory)

Two SMA connectors (subminiature A) for connecting an integrated edge detector.
Bend radius: ≥ 25 mm
Temperature: ≤ 100 °C
Lengths: 2 m, 3 m, 5 m

ID 687049-xx



Servo Amplifier for CNC

For the versions with CNC axis positioning, HEIDENHAIN supplies the appropriate servo amplifiers both for stepper motors and for servo motors. The cables for connection to the digital readout or the PC are included in delivery.

Servo amplifier for stepper motor (accessory)

For two-phase stepper motors,
Line voltage: 240 V
Rated voltage: 48 V–

For 2 axes:

Current per axis: ≤ 2.5 A
Power per axis: ≤ 120 W
ID 681 045-01

For 3 axes:

Current per axis: ≤ 1.67 A
Power per axis: ≤ 80 W
ID 681 045-02



Servo amplifier for servo motor (accessory)

For servo motors with brushes,
Line voltage: 240 V
Rated voltage: 48 V–

For 2 axes:

Continuous current per axis: ≤ 3 A
Rated power per axis: ≤ 150 W
ID 681 046-01

For 3 axes:

Continuous current per axis: ≤ 2 A
Rated power per axis: ≤ 100 W
ID 681 046-02



Interfaces

Digital Readouts

The digital readouts feature interfaces for encoders, for communication and for external components.



	ND 1102 ND 1103 ND 1104	ND 1202	ND 1203 ND 1204	ND 1302 ND 1303 ND 1304	ND 1404	ND 1202T	ND 2104 G ND 2108 G	
Encoders	1 V _{PP} or TTL							
Touch probe	● ¹⁾	–	–	–	–	● ¹⁾	–	● ²⁾
Video	–	–	–	● ³⁾	–	–	–	–
Fiber-optic cable Optical edge detector	–	Option	Upon request	–	●	–	–	–
Data	RS-232-C/V.24 and USB type A							
Light control	–	–	–	Option	–	–	–	–
Zoom	–	–	–	Option	–	–	–	–
CNC outputs	–	–	–	Option	Option	–	–	–
Foot switch	●	●	●	●	●	●	●	●
Remote keypad	●	●	●	●	●	–	●	●
Switching outputs	–	–	–	–	–	–	–	12 TTL
Switching inputs	–	–	–	–	–	–	–	5 TTL

● = Available

– = Not available

¹⁾ HEIDENHAIN touch probe or Renishaw touch probe

²⁾ Connection for two relay outputs or HEIDENHAIN touch probe or Renishaw touch probe

³⁾ S-Video and composite

IK 5000



Connections to the IK 5000 are made via its D-sub connectors. Depending on the version, further connections are made through one or two additional slot covers.

		IK 5293	IK 5294	IK 5394-EG	IK 5394-2D	IK 5493	IK 5494-2D	IK 5494-3D	IK 5594
	Slots ¹⁾	2	2	2	3	3	3	3	3
	Location								
Encoders for X,Y,Z	IK	1 V _{PP} or TTL							
CNC outputs	IK	–	–	–	–	●	●	●	●
Foot switch	IK	●	●	●	●	●	●	●	●
Fiber-optic cable	Slot L	–	–	● ²⁾	–	● ²⁾	–	–	–
Touch probe	Slot 1	● ³⁾	–	–	–	–	–	● ³⁾	TP 200
Light control	Slot 1	–	–	–	●	–	●	●	●
Zoom	Slot 2	–	–	–	●	–	●	●	●
Encoder for Q axis	Slot 2	–	1 V _{PP} or TTL						
Video	PC	–	–	–	USB camera ⁴⁾	–	USB camera ⁴⁾	USB camera ⁴⁾	USB camera ⁴⁾

● = Available

– = Not available

¹⁾ Including IK

²⁾ Connected directly to the IK PCB, special slot cover with cable guide included in delivery

³⁾ HEIDENHAIN touch probe or Renishaw touch probe

⁴⁾ Connected to the USB port of the PC

Please order the adapter cables necessary between the individual components separately.

Interfaces

Encoders

Depending on the versions, the digital readouts and the PC board are designed for encoders with 1 V_{PP} or TTL interface. Other interfaces are available upon request. A distribution cable is necessary in order to attach the encoders to the IK 5000.

Pin layout $\sim 1 V_{PP}$

Mating connector:
15-pin D-sub connector (male)

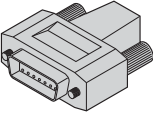
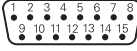
	Power supply				Incremental signals						Others
	4	12	2	10	1	9	3	11	14	7	5/6/8/ 13/15
$\sim 1 V_{PP}$	U _P	Sensor U _P	0V	Sensor 0V	A+	A-	B+	B-	R+	R-	/

Shield on housing; **U_P** = Power supply voltage

Sensor: The sensor line is connected in the encoder with the corresponding power line.

Vacant pins or wires must not be used!

Pin layout \square TTL

Mating connector:
9-pin D-sub connector (male)

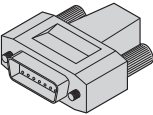
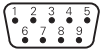
	Power supply			Incremental signals					
	7	6	1	2	3	4	5	8	9
\square TTL	U _P	0V	0V	U _{a1}	\overline{U}_{a1}	U _{a2}	\overline{U}_{a2}	U _{a0}	\overline{U}_{a0}

Shield on housing; **U_P** = Power supply voltage

Vacant pins or wires must not be used!

RFM

Resources For Manufacturing, Inc.

P.O. Box 751432 Dayton, OH 45475

Ph: (937) 436-4699 Fx: (937) 436-9244

Sales@RFMInc.net www.RFMInc.net